

New Products and Services

Company: **Autoclave Engineers**

Product: **High Pressure Air-Driven Pumps**

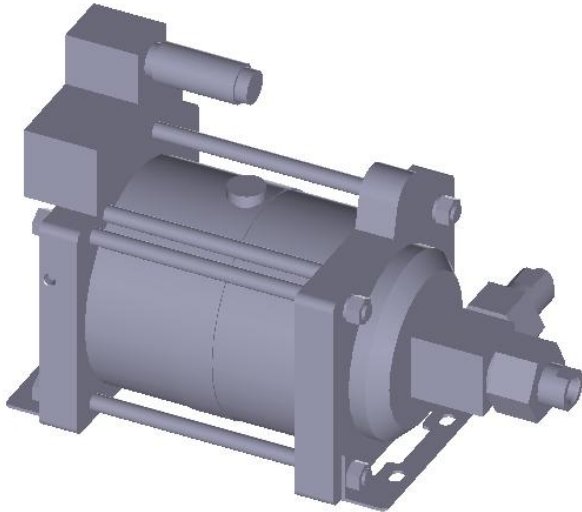

Autoclave Engineers Releases Air-Operated High Pressure Pump Models in 3D

Since we went live with our air-operated high pressure pump website we've continued to add additional air-to-pressure ratio options within each of the pump product groups. Today however, Autoclave Engineers is proud to announce the availability of 2D and 3D pump drawings/models that assist our customers in product layouts needing a high degree of accuracy. Each pump will have a link from its product specification page to these drawings that are available to download directly into any of 14 CAD software systems or be converted into one of 14 different file types that are suitable to import via download or email. Typical applications include; Pressure Test Stands, Burst Testing, Autofrettage , Chemical Injection, Gauge Testing, Work Holding, Jacking and Lifting Systems, and Valve Actuation. Manufacturers of all these systems and products will find these drawings easy to find and easy to use.

Visit our Website: www.autoclave.com
Contact us: ae_sales@snap-tite.com or (814) 860-5700

Company Information:

Name: Autoclave Engineers
Address: 8325 Hessinger Drive
City: Erie
State: PA
ZIP: 16509
Country: USA
Phone: 814-860-5700

URL: www.Autoclave.com

About Autoclave Engineers:

Since 1945, **Autoclave Engineers** has been the worldwide expert in the design and production of high pressure valves, fittings, tubing and now air-operated pumps and pump systems. We manufacture our products to be safe and reliable while operating under extreme pressure and temperature conditions. With pressures up to 150,000 psi (10345 bar), we are the first choice for the petrochemical, chemical, waterblast, waterjet, and oil & gas industries.