

Air-Driven, High Flow, High Pressure Liquid Pump

Series ASL10-01

Single-Acting, Single Piston Air Drive

Technical Data: Liquid Side Specifications

- Service: *Oil, Water or Water/Oil mixture and other fluids depending on material compatibility*
- Maximum Outlet Pressure: *1,600 psi (110 bar)*
- Air to Liquid Pressure Ratio: *1:11*
- Isolation Chamber (prevents process contamination of air section): *Optional*
- Volume Displacement Per Stroke: *5.22 in³ (85.5 cm³)*
- Inlet Connection: *1" FNPT*
- Outlet Connection: *1/2" FNPT Female NPT*
(Contact Autoclave Engineers for Additional Options)

Technical Data: Air Side Specifications

- Air Drive Pressure Range: *15-150 psi (1-10 bar)* *See note1
- Nominal air pressure required for 1,600 psi (110 bar) output pressure is 145 psi (10 bar)
- Inlet Port: *1/2" FNPT*
- Pilot Port: *1/8" FNPT (unregulated air)*
- Exhaust Port (muffler removed): *1/2" FNPT*
- Air Consumption @ 90 psi: *69 SCFM*
- Prelubricated at Factory

General Specifications

- Maximum Operating Temperature: *0-140° F (-18° to 60° C)*
- Net Weight without Isolation Chamber: *38 lbs. (17.2 kg)*
- Net Weight with Isolation Chamber: *Consult Factory*
- Pressure Head: *15-5 PH Stainless Steel*
- Stainless steel plunger utilizing a proprietary multi-layer carbon based coating with diamond like carbon exterior layer - 3 times the hardness of stellite with a coefficient of friction equal to/less than PTFE
- Check Valve Glands: *316 Stainless Steel*
- Liquid Seal: *See Ordering Guide for Options*
- Air Drive Seals: *Buna N*

Notes:

1. *Maximum air drive pressure is limited by maximum output pressure.*
2. *Alternative materials for wetted parts and seals are available, please contact Autoclave Engineers for additional information.*



Fluid Components
Division of Snap-tite, Inc.
www.autoclave.com

MADE IN THE U.S.A.

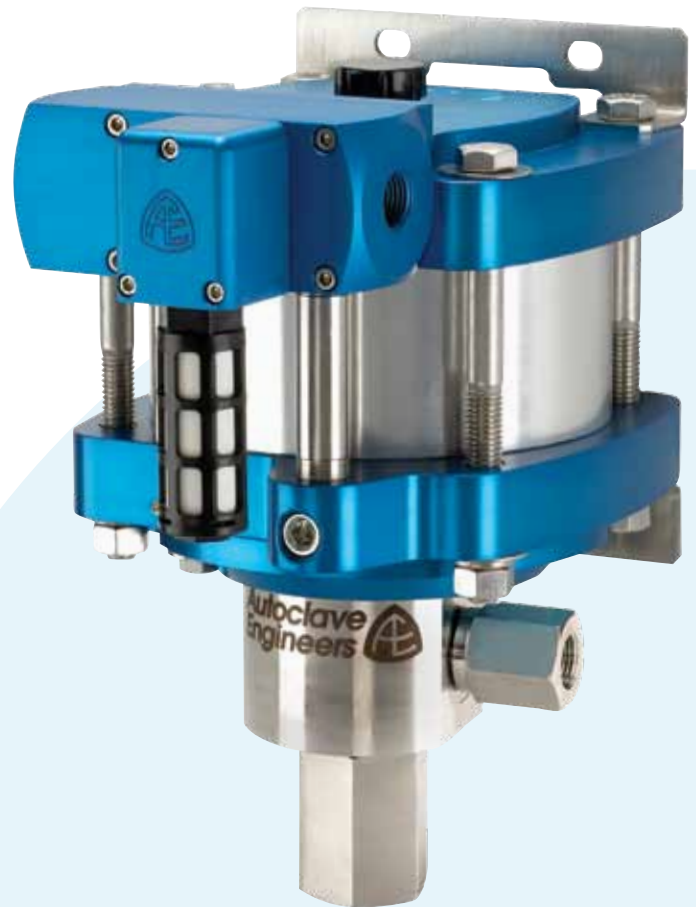

Single-Acting, Single Piston Air Drive Pump

Bottom Inlet Shown

Ordering Guide:

For complete information on available pump options, contact Autoclave Engineers.

Typical catalog number: **ASL10-01SNPV**

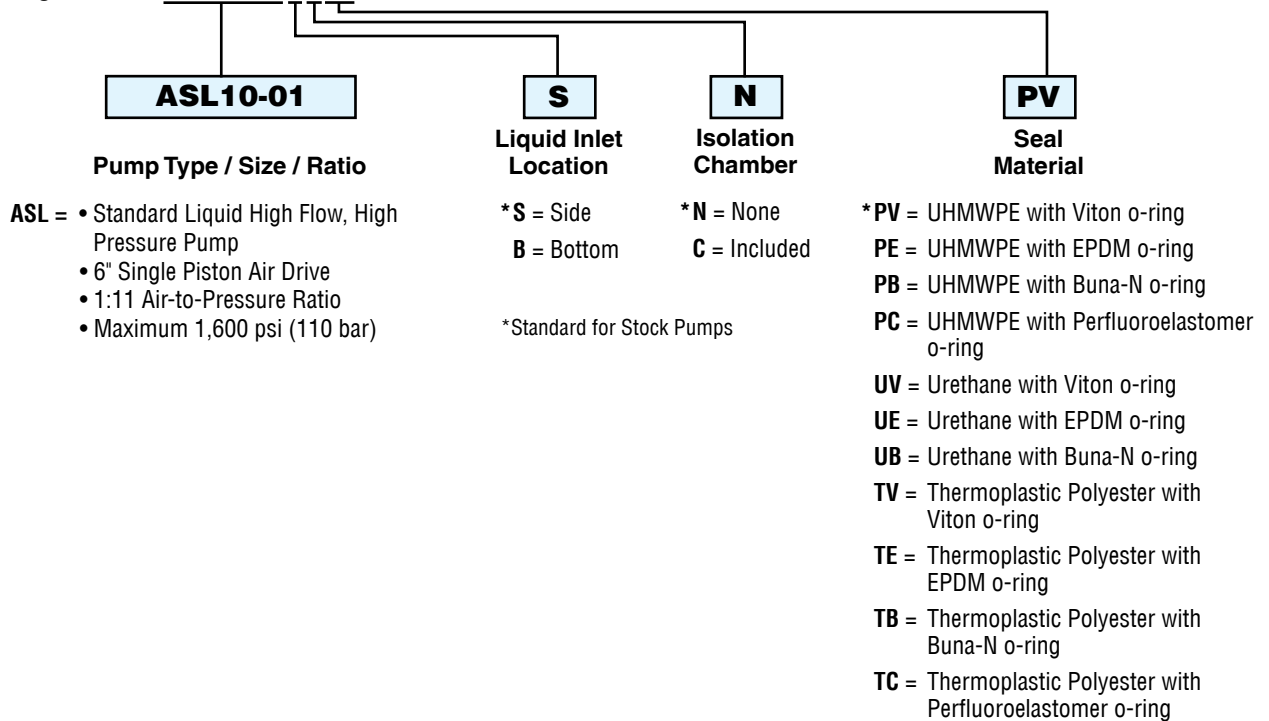

Flow Rate vs. Outlet Pressure:

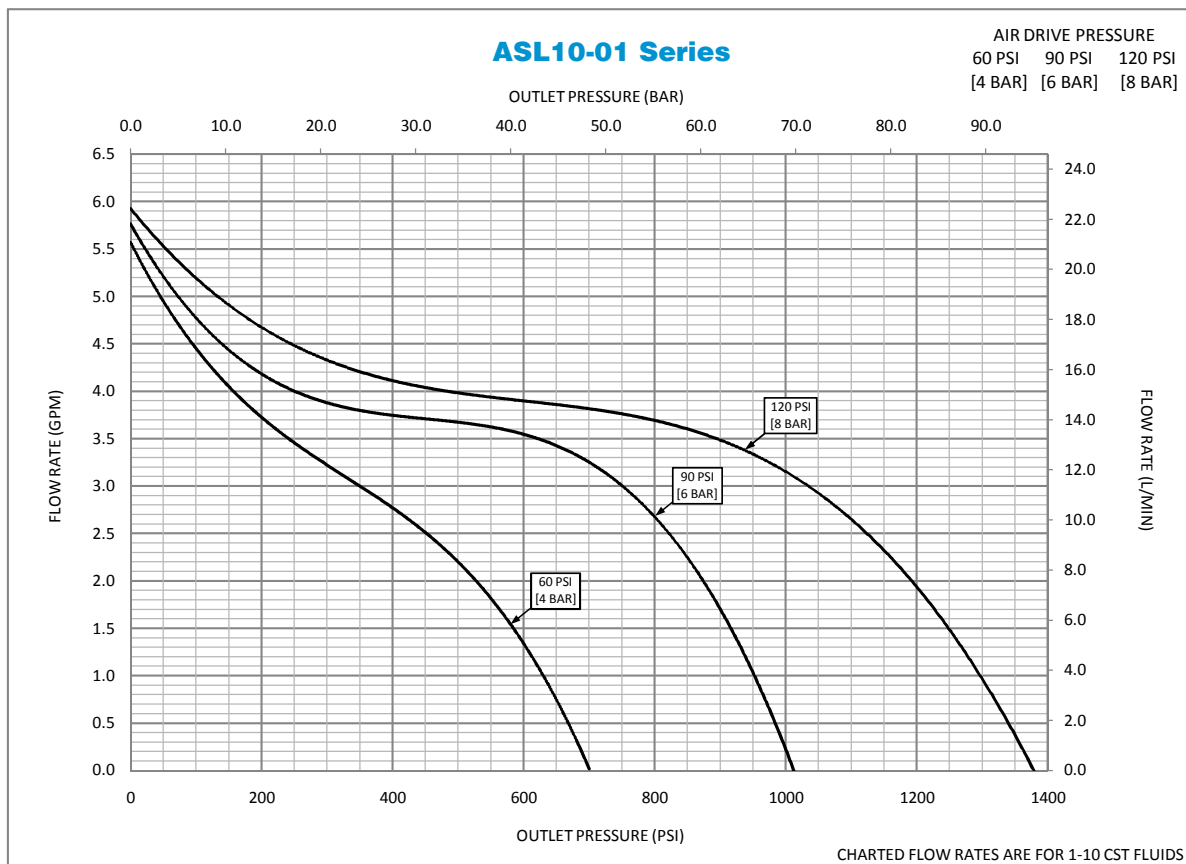

Actual flow rates will vary depending on air flow capacity, downstream flow restrictions, and fluid type.

Dimensional Data:

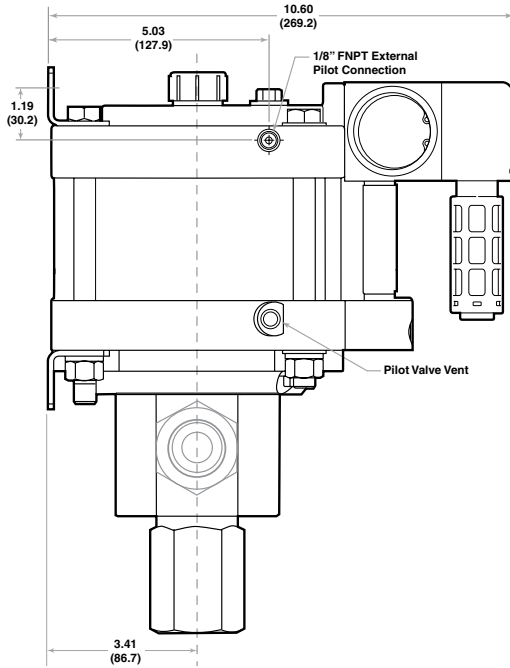

Left View

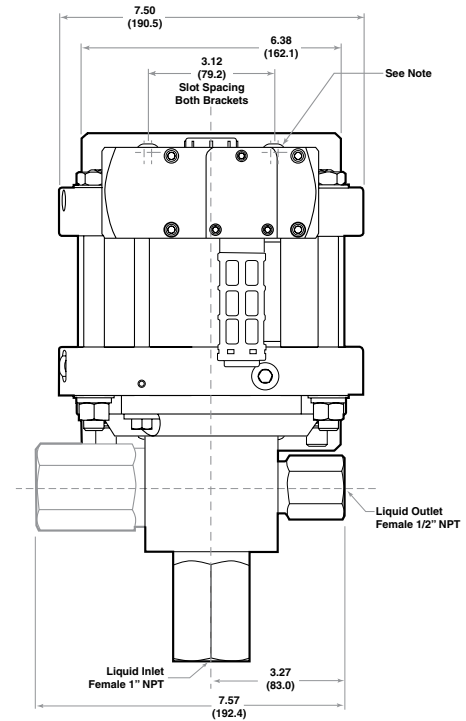

Front View

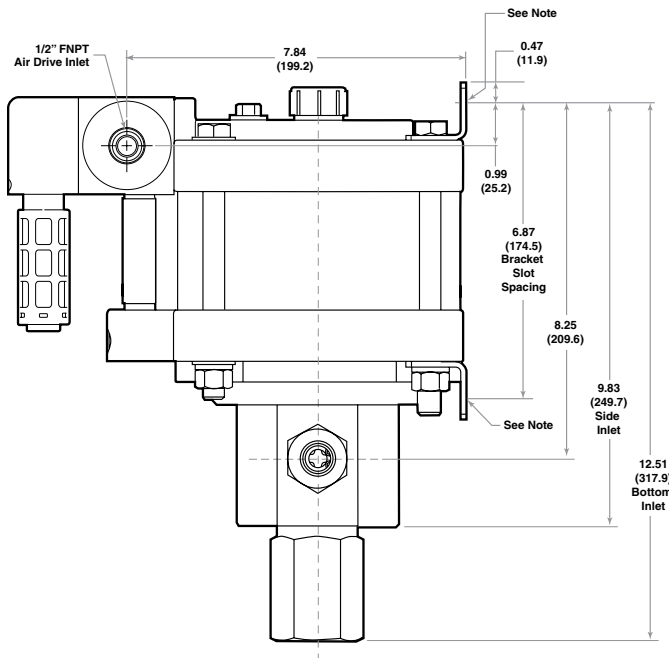

Right View

Optional Isolation Chamber

Contact factory for mounting dimensions of the isolation chamber version.

Note:

Each Mounting Bracket includes (2) x 13/32" (10.32) Slots for 3/8" Bolts.
 Bottom Inlet Pump Head and Side Inlet Pump Head are mutually exclusive.
 All dimensions are for reference only and are subject to change without notice.

Primary Dimensions: Inches
 Secondary Dimensions: (Millimeters)

Accessories Available:

- Air Control Packages
- Pneumatic Pilot switches and Solenoid Valves
- Stroke Counter
- Relief Valve / Safety Heads
- Complete line of High Pressure Components - Valves, Fittings & Tubing
- Spare Parts
- Service



Typical Air Control Package



For complete information on available high pressure accessories, please contact Autoclave Engineers.

All general terms and conditions of sale, including limitations of our liability, apply to all products and services sold.

! WARNING !

FAILURE OR IMPROPER SELECTION OR IMPROPER USE OF THE PRODUCTS AND/OR SYSTEMS DESCRIBED HEREIN OR RELATED ITEMS CAN CAUSE DEATH, PERSONAL INJURY AND/OR PROPERTY DAMAGE.

This document and other information from Snap-tite, Inc., its subsidiaries and authorized distributors, provides product and/or system options for further investigation by users having technical expertise. It is important that you analyze all aspects of your application and review the information concerning the product or system in the current product catalog.

Due to the variety of operation conditions and applications for these products or systems, the user, through its own analysis and testing, is solely responsible for making the final selection of the products and systems and assuring that all performance, safety and warning requirements of the application are met.

The products described herein, including without limitation, product features, specifications, designs, availability and pricing, are subject to change by Snap-tite, Inc. and its subsidiaries at any time without notice.

 **Snap-tite**
EUROPE

Industrial Estate
Whitemill-Wexford
Republic of Ireland
PH: 353 53 914 1566 FAX: 353 53 914 1582
e-mail: ste_sales@snap-tite.com
www.snap-tite.com

Autoclave Engineers 

Fluid Components
Division of Snap-tite, Inc.

8325 Hessinger Drive
Erie, Pennsylvania 16509-4679 USA
PH: 814-860-5700 FAX: 814-860-5811
e-mail: ae_sales@snap-tite.com
www.autoclave.com